



Shengzhen XinLichuan Electric Co.,Ltd



LCDA2260E Digital hybrid servo

An instruction manual



Catalog

Installation	2
1. Electrical index	2
2. Environmental indicator	2
3. Installation dimension drawing.....	2
Connection.....	3
1. Drive terminal description	3
2. Control port connection mode	4
3. Sequence diagram of control signals	5
Parameter setting	5
1. Debug panel presentation	5
2. Data monitoring	6
3. Operation process	7
4. Specific parameter description	8

Installation

1 Electrical index

- Voltage input range : AC : 150V~230V (General connection 220V)
- Maximum output current : 6A
- Pulse form : Pulse + direction、CW/CCW
- Logic input current : 10~20mA
- Pulse corresponding frequency : 0~200kHz
- insulation resistance : 500MΩ

2 Environmental indicator

- Storage temperature: -20℃~80℃
- Service temperature: 0℃~55℃
- Use humidity : 90%RH (No condensation)
- Vibration frequency : less than 0.5G (49 m/s²) 10Hz~60Hz (Discontinuous operation)

3 Installation dimension drawing (unit mm)

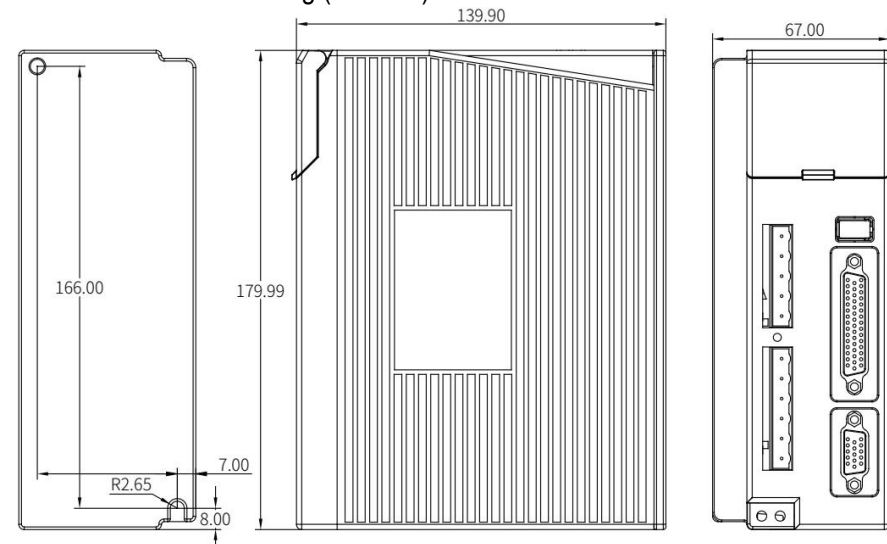

Figure 1 Drive mounting dimensions drawing

Connection

1 Drive terminal description

1) Power fragment definition

Serial number	Symbol	Function definition
1	R	Main circuit, power supply terminals, general wiring, AC AC220V
2	S	
3	NC	
4	BR	The external braking resistor is connected between the BR and the P+
5	P+	
6	U	Motor power line terminal wiring color see motor label
7	V	
8	W	
9	PE	Ground
10	r	Control power terminals, general AC AC220V
11	s	

2) Drive control terminal definition (44 pin DB plug)

Pin	Symbol	Explain	Pin	Symbol	Explain
3	PUL+	Pulse input positive	8	ALM-	Alarm output negative
4	PUL-	Pulse input negative	9	Pend+	Location completed output positive
5	DIR+	Directional input	10	Pend-	Location complete output negative
6	DIR-	Direction input negative	11	ENA+	Enable input positive
7	ALM+	Alarm output positive	12	ENA-	Enable input negative

3) Driver encoder terminal definition (15 pin DB plug)

Pin	Symbol	Colour	Explain
1	EA+	Black	Encoder A signal positive

2	EB+	Yellow	Encoder B signal positive
3	GND	White	Encoder power ground
11	EA-	Blue	Encoder A negative signal
12	EB-	Green	Encoder B negative signal
13	VCC	Red	Encoder +5V input

2、Control port limit mode

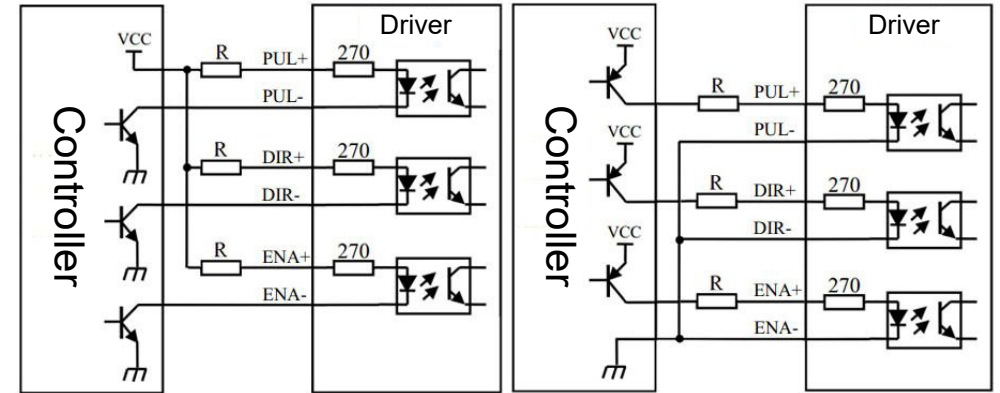

Figure 2 Common anode connection

Figure 3 Common cathode connection

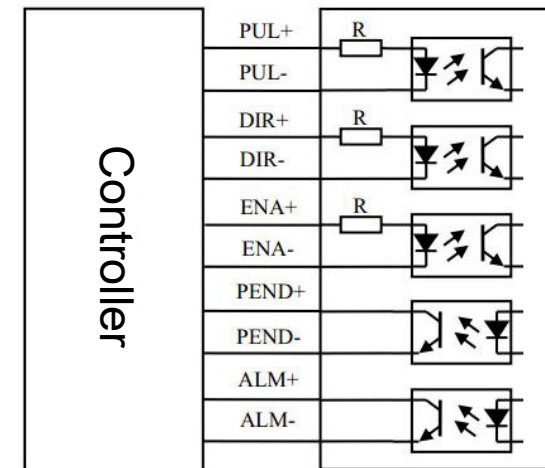

Figure 4 Differential signal input and output signal receiving

Note: When the control signal voltage is $VCC = 24V$, the current limiting resistor $R = 3K$;
 When the control signal voltage is $VCC = 5V$, the current limiting resistor $R = 0$;

3、Sequence diagram of control signals

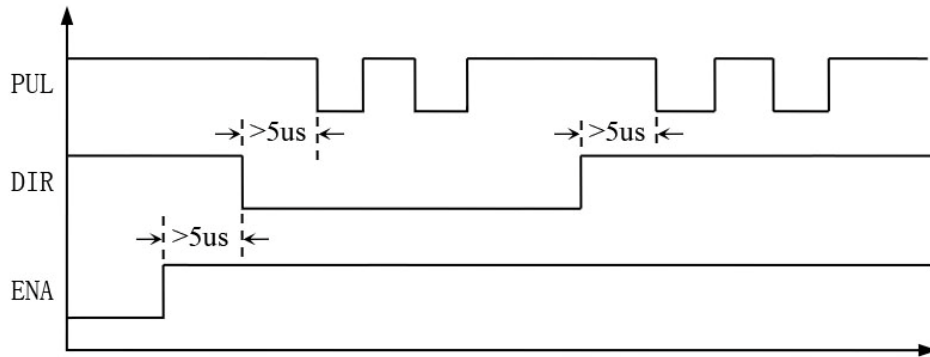

Figure 5 Control signal sequence diagram

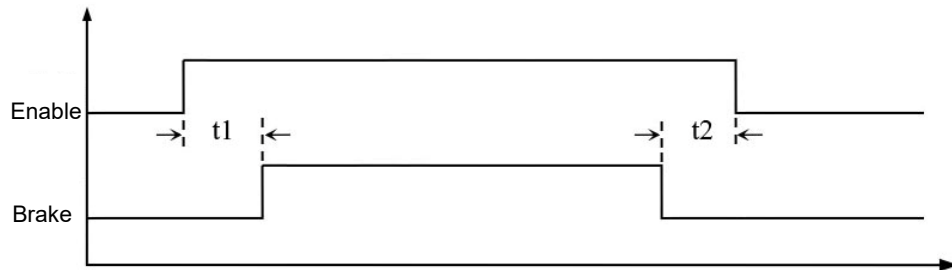

Figure 6 Motor brake control signal timing diagram

$t1$: Brake open delay time

$t2$: The closing time of the brake delay

Parameter setting

This series of drives allows you to set parameters directly through the button panel of the drive. The debug panel and debugging steps are as follows:

1、Debug panel presentation

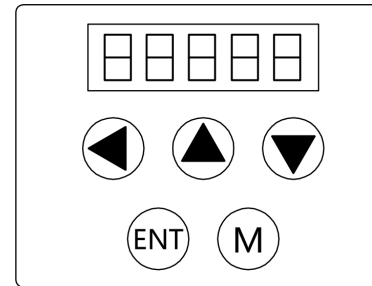

Key mark	Button description
	The input bit (blinking) is shifted left
	Toggle submenu, add value
	Toggle submenu, reduce numeric value
	Enter the submenu and determine the input
	Switching between modes

2、Data monitoring

LED display	Explain
	The current position error is converted to the code line number
	Current speed feedback (RPM)
	Current speed given (RPM)
	The number of pulses after the frequency doubling of the current position feedback encoder 4 starts from the initialization of the upper motor
	The number of raw pulses given at the current position starts from initialization after power up
	Current peak (mA)
	Current fault value. 01: excessive current 02: Overvoltage ; 04: The position error is over limit

3. Operation process

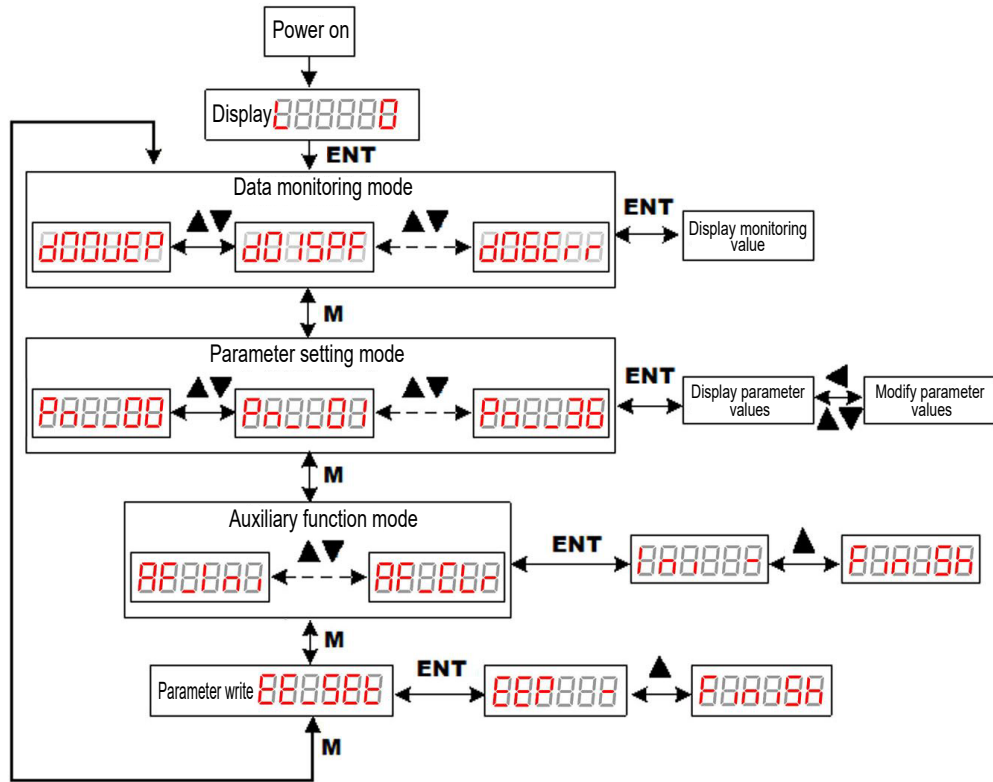

Restore factory settings: Press (M) Key switch to “AF_Ini”, Then press (ENT) key, display “InI -”, Then Press (▲) key, Appear “FinISH”, Indicates that the settings are complete.

Clear alarm record: Press (M) Key switch to “AF_CLR”, Then press (ENT) key, display “CLr-”, Then Press (▲) key, Appear “FinISH”, Indicates that the settings are complete.

Parameter write: Press (M) Key switch to “EE_Set”, Then press (ENT) key, display “EEP -”, Then Press (▲) Key 5 seconds, Appear “FinISH”, Indicates that the settings are complete.

4. Specific parameter description

Serial number	Name	Default value	Range	Remarks
0	The number of pulses per revolution of the motor	4000	400-60000	Pulse / turn
1	Number of pulses per revolution of the encoder	4000	1000-60000	Pulse / turn
2	Standby current percentage	40	1-100	Percentage of standby current of motor
3	Percentage of running current	100	1-100	Percentage of maximum running current of motor
4	Input filtering enable	0	0-1	0: Input pulse not filtered 1: Input pulse filtering
5	Input filtering time	5000	50-51200	Input pulse filtering time Company us
6	Fault output resistor setting	0	0-1	0: Fault time coupling cutoff 1: Fault time coupled conduction
7	Open closed loop control mode setting	1	0-1	0: Open-loop control 1: Closed-loop control
8	Self-tuning selection	1	0-1	1: Automatic setting of motor current loop parameters
9	Current loop Kp	1000	300-32767	The current loop proportional coefficient (auto tuning of the effective parameter automatic gain)
10	Current loop Ki	200	10-32767	The integral coefficient of the current loop (auto tuning is valid and the parameter is automatically acquired)
11	Manufacturer parameter 0	512		Manufacturer
12	Position loop Kp	1300	300-32767	Coefficient of position loop ratio
13	Position loop Ki	200	20-32767	Integral coefficient of position loop
14	Position loop Kd	200	20-32767	Differential coefficient of position ring
15	Position loop compensation	250	20-32767	Retardation coefficient of position loop
16	Low velocity vibration resistance coefficient	0	0—32767	Low speed vibration elimination coefficient
17	Position error limit	4000	1-65535	Position tracking error alarm threshold
18	Position integration delay time	10	0-10000	ms
19	Enable effective level	1	0-1	0: Optically coupled to enable 1: The optocoupler is not turned on for enabling
20	Non enabled motor status	0	0-1	0: Loose shaft of motor when not allowed 1: Lock shaft of motor without making time

21	Enable clear fault selection	0	0-1	0: No clear fault is allowed 1: Allow
22	Manufacturer parameter 1	0	0-1	Manufacturer parameter
23	Manufacturer parameter 2	0	0-1	Manufacturer parameter
24	Manufacturer parameter 3	0	0-1	Manufacturer parameter
25	Single and double pulse selection	0	0-1	0: Pulse direction control mode 1: Double pulse control mode
26	Pulse effective edge selection	0	0-1	0: Pulse rising edge is valid 1: The pulse falling edge is valid
27	Positive direction level setting	1	0-1	0: Directional level positive logic 1: Reverse direction level logic
28	Input pulse cutoff frequency setting	0	0-1	0: 200KHz; 1: 500KHz
29	Test run acceleration	200	1-2000	Rps/s
30	Maximum speed of test run	100	1-5000	0.01rps
31	Trial run distance	100	1-65535	0.01r
32	Test run times	1	1-65535	Run times
33	Starting speed of test run	1	0-1	0: Reverse direction start 1: Positive start
34	Test run interval time	100	1-65535	The interval between multiple trial runs Company : ms
35	Does the trial run go back and forth	1	0-1	0: One-way 1: Return
36	Start and stop test set	0	0-1	1: Startup attempt run